

CMS3588A6-HF

N and P-Channel
RoHS Device
Halogen Free



Features

- Simple drive requirement.
- Low gate charge.
- Low on-resistance.
- Fast switching speed.

Mechanical data

- Case: DFN2X2-6L, molded plastic.

Circuit Diagram

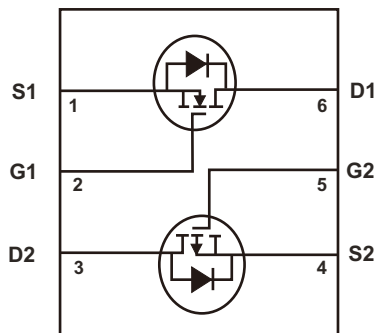

G: Gate S: Source D: Drain

- Pin 1. Source1 (S1)
- Pin 2. Gate1 (G1)
- Pin 3. Drain2 (D2)
- Pin 4. Source2 (S2)
- Pin 5. Gate2 (G2)
- Pin 6. Drain1 (D1)

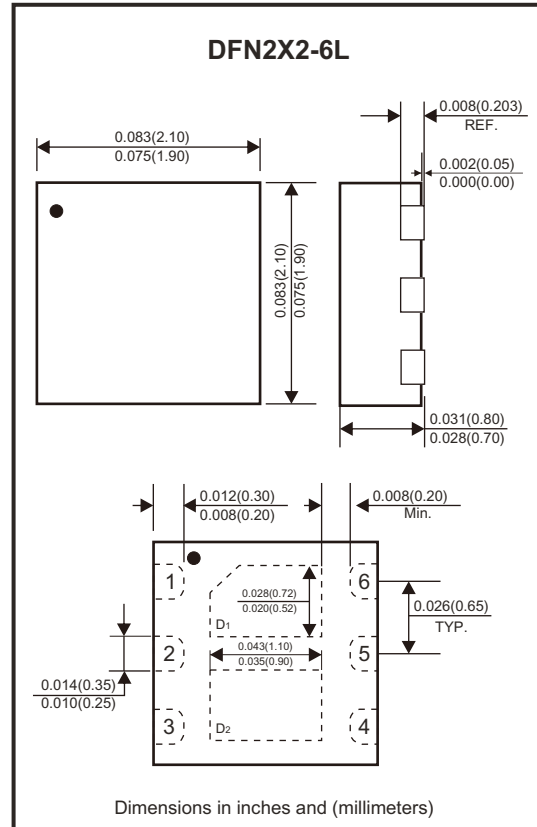

Maximum Ratings (at $T_A=25^\circ\text{C}$ unless otherwise noted)

Parameter		Symbol	N-Channel	P-Channel	Unit
Drain-source breakdown voltage		V_{DS}	14	-14	V
Gate-source voltage		V_{GS}	± 8	± 8	V
Continuous drain current	$T_A=25^\circ\text{C}$ (Note 1)	I_D	6	-4	A
	$T_A=70^\circ\text{C}$ (Note 1)	I_D	4.8	-3.2	A
Pulsed drain current (Note 2)		I_{DM}	30	-20	A
Total power dissipation (Note 1)		P_D	1.38		W
Linear derating factor			0.01		W/ $^\circ\text{C}$
Maximum thermal resistance	Junction to case	$R_{\theta JC}$	80		$^\circ\text{C}/\text{W}$
	Junction to ambient (Note 3)	$R_{\theta JA}$	90		
Operating junction temperature range		T_J	-55 to +150		$^\circ\text{C}$
Storage temperature range		T_{STG}	-55 to +150		$^\circ\text{C}$

Note: 1. Surface mounted on 1 in² copper pad of FR-4 board, $t \leq 5$ sec

2. Pulse width limited by maximum junction temperature.

3. Surface mounted on 1 in² copper pad of FR-4 board, $t \leq 5$ sec; 195 $^\circ\text{C}/\text{W}$ when mounted on minimum copper pad.

Company reserves the right to improve product design, functions and reliability without notice.

REV:B

N-Channel Electrical Characteristics (at TA=25°C unless otherwise noted)

Parameter	Symbol	Conditions	Min	Typ	Max	Unit
Static						
Drain-source breakdown voltage	BV _{DSS}	V _{GS} = 0V, I _D = 250μA	14			V
Temperature coefficient of breakdown voltage	ΔBV _{DSS} /ΔT _J	Reference to 25°C, I _D = 1mA		8		mV/°C
Gate-source threshold voltage	V _{GS(th)}	V _{DS} = V _{GS} , I _D = 250μA	0.5	0.7	1.2	V
Gate-source leakage	I _{GSS}	V _{GS} = ±8V, V _{DS} = 0			±100	nA
Zero gate voltage drain current	I _{DSS}	V _{DS} = 12V, V _{GS} = 0			1	μA
	I _{DSS}	V _{DS} = 10V, V _{GS} = 0, T _J = 70°C			10	μA
Drain-source on-state resistance	* R _{DS(on)}	V _{GS} = 4.5V, I _D = 5A		16.6	26	mΩ
		V _{GS} = 2.5V, I _D = 4.6A		23.7	33	
		V _{GS} = 1.8V, I _D = 4.1A		38.5	74	
		V _{GS} = 1.5V, I _D = 2A		66.3	114	
Forward transconductance	* G _{FS}	V _{DS} = 5V, I _D = 3A		5.6		S
Dynamic						
Input capacitance	C _{iss}	V _{DS} = 10V, V _{GS} = 0V, f = 1MHz		407		pF
Output capacitance	C _{oss}			115		
Reverse transfer capacitance	C _{rss}			100		
Turn-on delay time	* t _{d(on)}	V _{DS} = 10V, I _D = 1A, V _{GS} = 5V, R _G = 3.3Ω		5		nS
Turn-on rise time	* t _r			18.8		
Turn-off delay time	* t _{d(off)}			49.6		
Turn-off fall time	* t _f			30.8		
Total gate charge	* Q _g	V _{DS} = 10V, I _D = 3A, V _{GS} = 4.5V		6.5		nC
Gate-source charge	* Q _{gs}			0.7		
Gate-drain charge	* Q _{gd}			2.3		
Gate resistance	R _g	f=1MHz		1		Ω
Source-Drain Diode						
Diode forward voltage	* V _{SD}	V _{GS} = 0V, I _S = 5.2A		0.87	1.2	V

* Pulse test: Pulse width ≤ 300μs, Duty cycle ≤ 2%.

P-Channel Electrical Characteristics (at T_A=25°C unless otherwise noted)

Parameter	Symbol	Conditions	Min	Typ	Max	Unit
Static						
Drain-source breakdown voltage	BV _{DSS}	V _{GS} = 0V, I _D = -250μA	-14			V
Temperature coefficient of breakdown voltage	ΔBV _{DSS} /ΔT _J	Reference to 25°C, I _D = 1mA		-5		mV/°C
Gate-source threshold voltage	V _{GS(th)}	V _{DS} = V _{GS} , I _D = -250μA	-0.4		-1.0	V
Gate-source leakage	I _{GSS}	V _{GS} = ±8V, V _{DS} = 0			±100	nA
Zero gate voltage drain current	I _{DSS}	V _{DS} = -12V, V _{GS} = 0			-1	μA
	I _{DSS}	V _{DS} = -10V, V _{GS} = 0, T _J = 70°C			-10	μA
Drain-source on-state resistance	* R _{DS(on)}	V _{GS} = -4.5V, I _D = -3.6A		43	56	mΩ
		V _{GS} = -2.5V, I _D = -3.2A		63.6	79	
		V _{GS} = -1.8V, I _D = -1A		86.5	168	
		V _{GS} = -1.5V, I _D = -1A		153.3	276	
Forward transconductance	* G _{FS}	V _{DS} = -5V, I _D = -2A		5.6		S
Dynamic						
Input capacitance	C _{iss}	V _{DS} = -10V, V _{GS} = 0V, f = 1MHz		561		pF
Output capacitance	C _{oss}			153		
Reverse transfer capacitance	C _{rss}			142		
Turn-on delay time	* t _{d(on)}	V _{DS} = -10V, I _D = -1A, V _{GS} = -5V, R _G = 3.3Ω		5		nS
Turn-on rise time	* t _r			18.8		
Turn-off delay time	* t _{d(off)}			49.6		
Turn-off fall time	* t _f			30.8		
Total gate charge	* Q _g	V _{DS} = -10V, I _D = -2A, V _{GS} = -4.5V		8		nC
Gate-source charge	* Q _{gs}			1		
Gate-drain charge	* Q _{gd}			2.8		
Gate resistance	R _g	f=1MHz		9.3		Ω
Source-Drain Diode						
Diode forward voltage	* V _{SD}	V _{GS} = 0V, I _S = -3.4A		-0.9	-1.2	V

* Pulse test: Pulse width ≤ 300μs, Duty cycle ≤ 2%.

N-Channel Typical Characteristic Curves (CMS3588A6-HF)

Fig.1 - Typical Output Characteristics

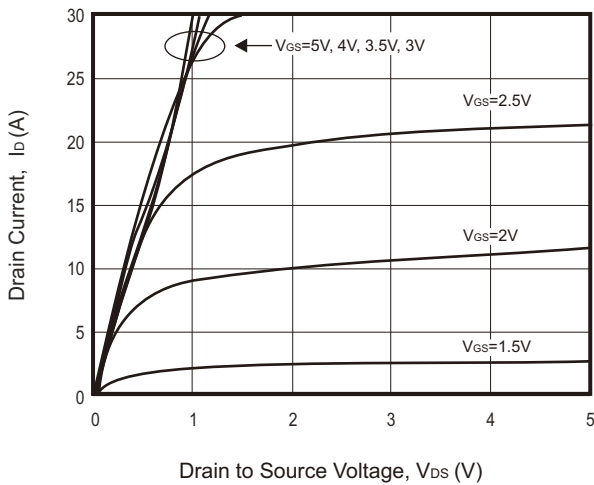

Fig.2 - Static Drain-Source On-State Resistance VS Drain Current

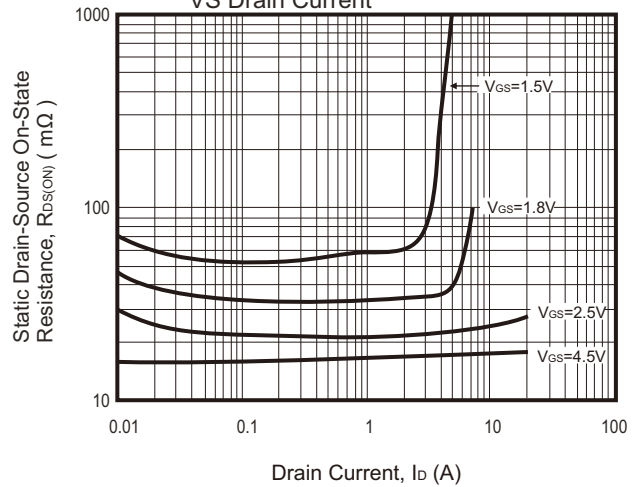

Fig.3 - Static Drain-Source On-State Resistance VS. Gate-Source Voltage

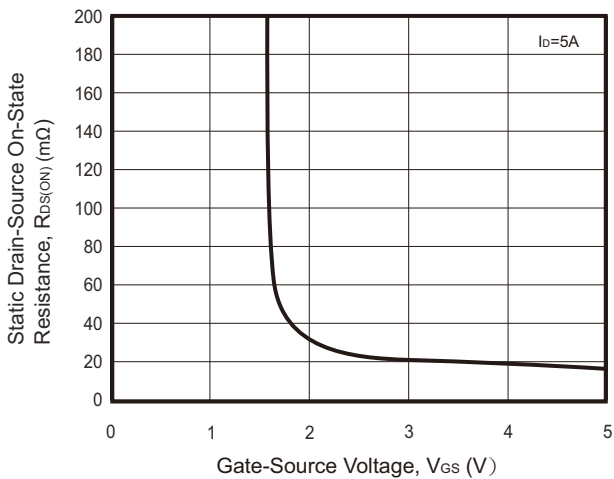

Fig.4 - Capacitance VS Drain-Source Voltage

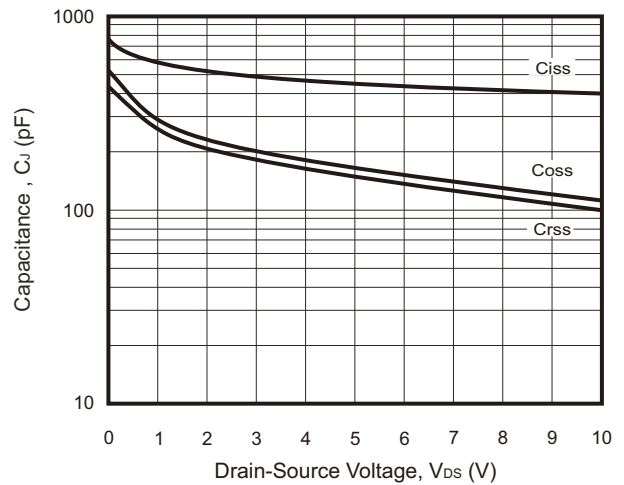

Fig.5 - Gate Charge Characteristics

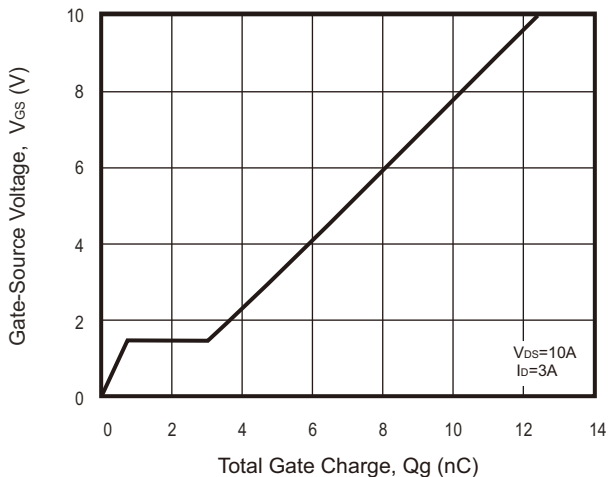
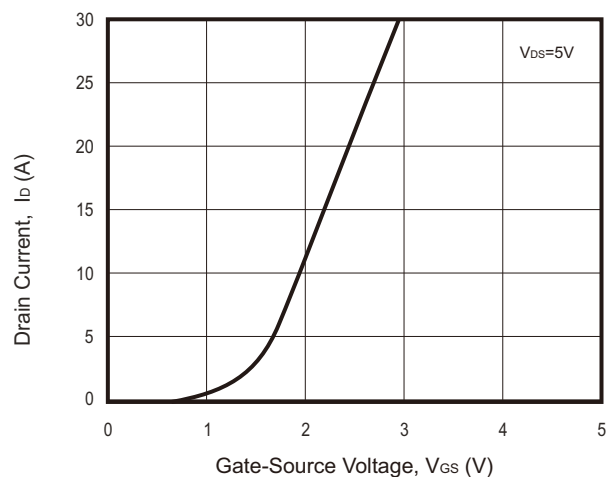

Fig.6 - Typical Transfer Characteristics



P-Channel Typical Characteristic Curves (CMS3588A6-HF)

Fig.1 - Typical Output Characteristics

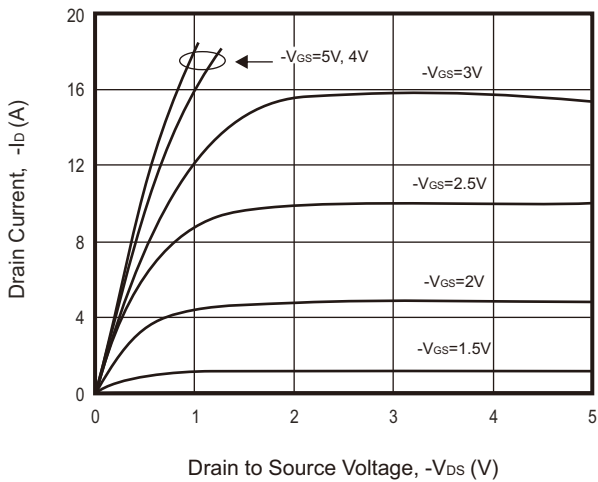

Fig.2 - Static Drain-Source On-State Resistance VS Drain Current

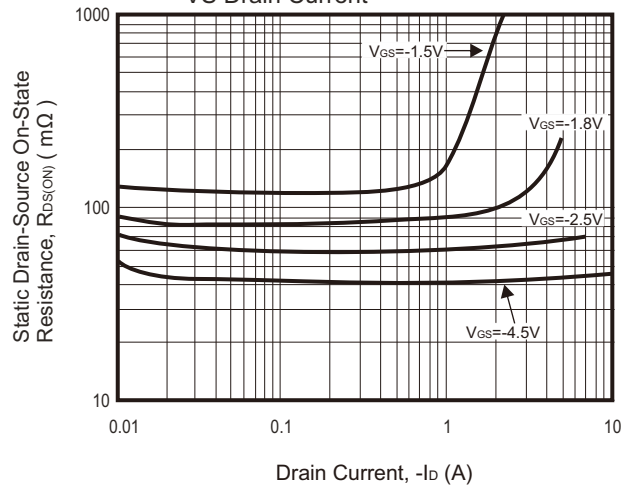

Fig.3 - Static Drain-Source On-State Resistance VS. Gate-Source Voltage

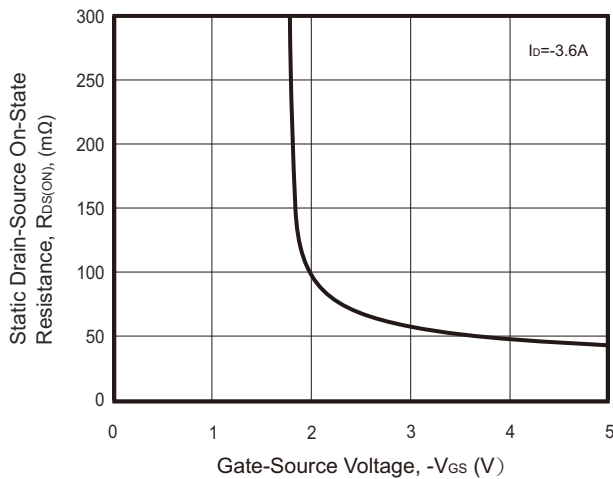

Fig.4 - Capacitance VS Drain-Source Voltage

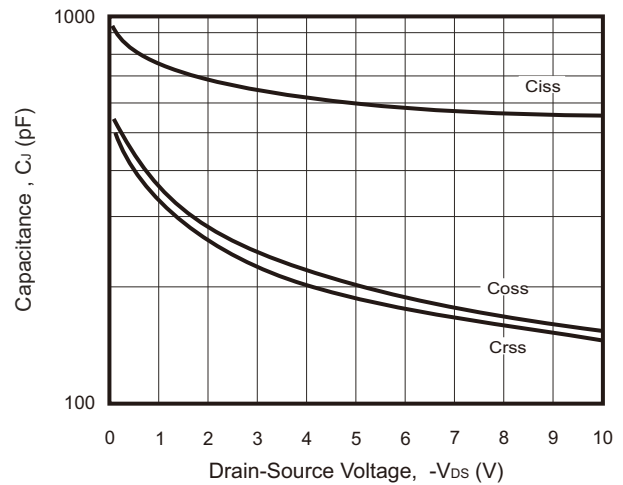

Fig.5 - Gate Charge Characteristics

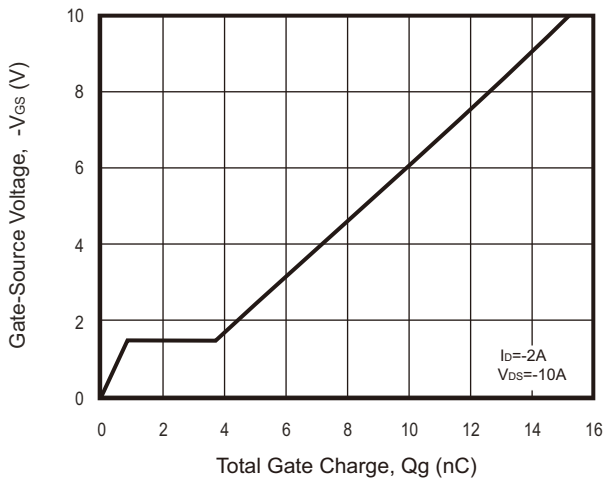
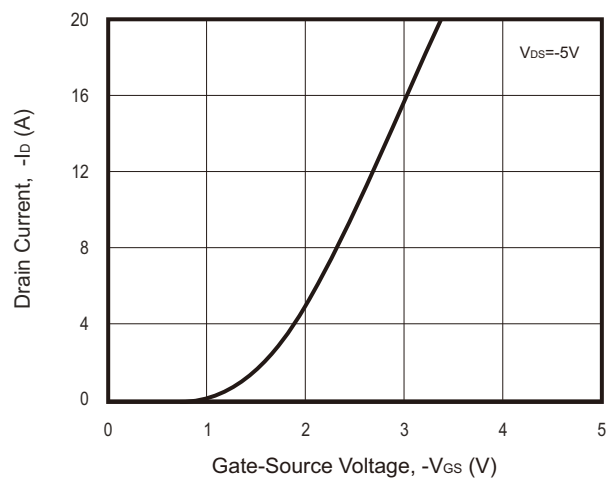
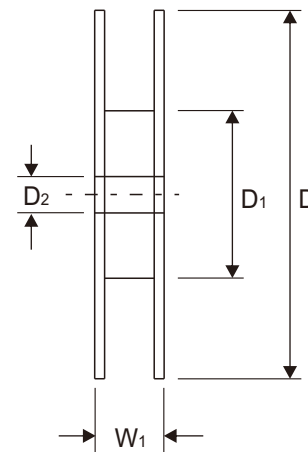
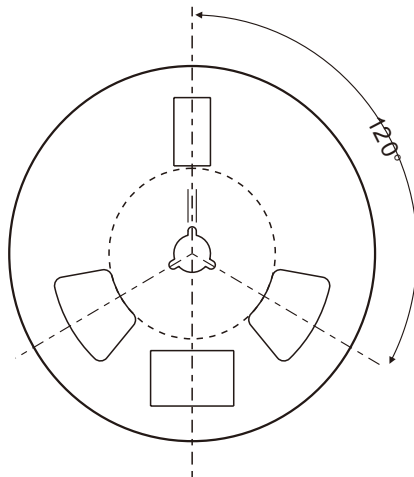
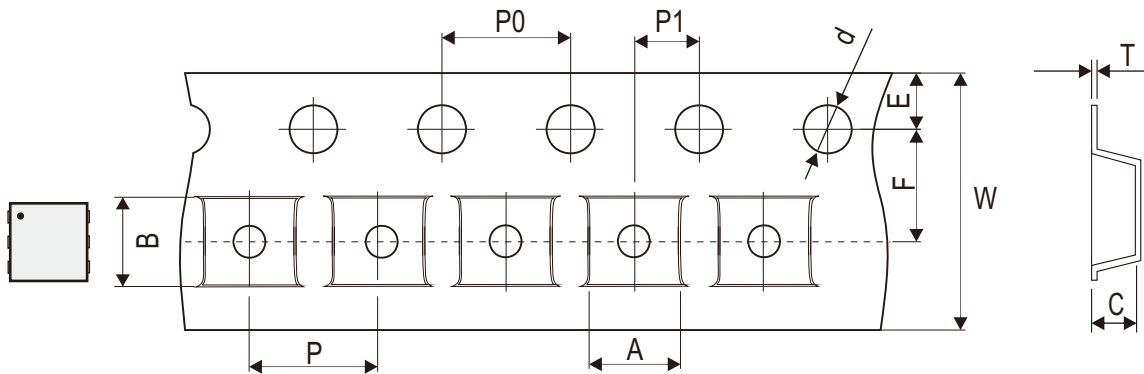

Fig.6 - Typical Transfer Characteristics



Reel Taping Specification



DFN2X2-6L	SYMBOL	A	B	C	d	D	D1	D2
	(mm)	2.30 ± 0.05	2.30 ± 0.05	1.10 ± 0.05	1.50 + 0.10 - 0.00	180.00 + 0.00 - 3.00	60.00 ± 0.50	13.00 ± 0.20
	(inch)	0.091 ± 0.002	0.091 ± 0.002	0.043 ± 0.002	0.059 + 0.004 - 0.00	7.087 + 0.00 - 0.118	2.362 ± 0.020	0.512 ± 0.008

DFN2X2-6L	SYMBOL	E	F	P	P0	P1	T	W	W1
	(mm)	1.75 ± 0.10	3.50 ± 0.05	4.00 ± 0.10	4.00 ± 0.10	2.00 ± 0.05	0.27 ± 0.02	8.00 + 0.20 - 0.10	13.10 ± 1.30
	(inch)	0.069 ± 0.004	0.138 ± 0.002	0.157 ± 0.004	0.157 ± 0.004	0.079 ± 0.002	0.011 ± 0.001	0.315 + 0.008 - 0.004	0.516 ± 0.051

Marking Code

Part Number	Marking Code
CMS3588A6-HF	588B

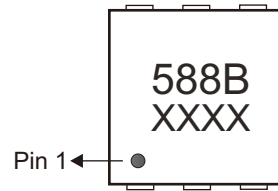

XXXX = Control code

Suggested P.C.B. PAD Layout

SIZE	DFN2X2-6L	
	(mm)	(inch)
A	1.70	0.067
B	0.85	0.033
C	1.10	0.043
D	1.40	0.055
E	2.00	0.079
F	0.40	0.016
G	0.65	0.026
H	0.30	0.012
I	0.77	0.030
J	0.16	0.006

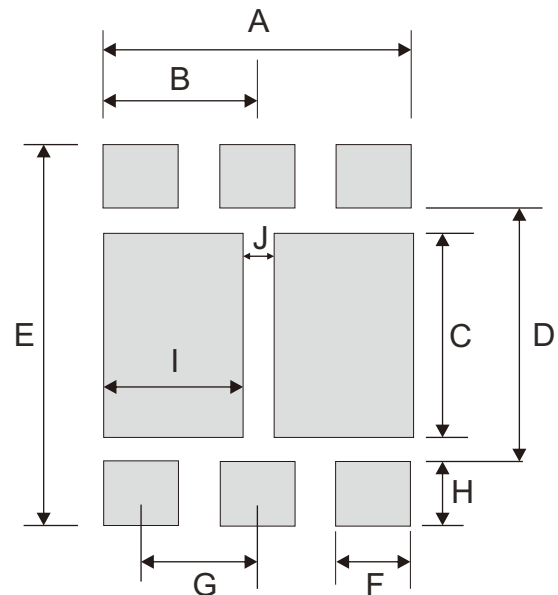

Standard Packaging

Case Type	REEL PACK	
	REEL (pcs)	Reel Size (inch)
DFN2X2-6L	3,000	7